

Orion SGM100

Pedestrian Swing Gate

Product Data Sheet

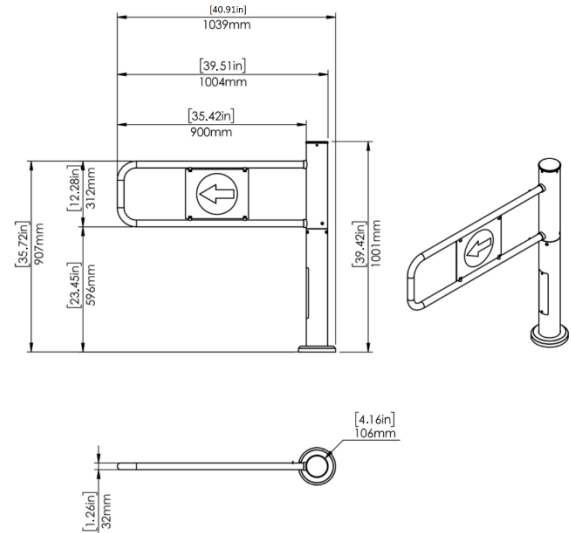

FEATURES

- Hand operated with auto closing.
- Extremely robust and water resistant.
- Unidirectional or bidirectional operation.
- Fail-safe operation as standard. (Optional fail-locked)
- Can be installed in conjunction with full height pedestrian doors, turnstiles, and Durapods.

MATERIALS

- Stainless steel.

SPECIFICATIONS

- Post Height: 1000 mm / 39.37".
- Passage Width: 530 mm / 20.86".
- Barrier Length: 900 mm / 35.43".
- Barrier Diameter: 105 mm / 4.13".
- Weight: 18 KG / 40 lbs.

DIMENSIONS

- WS 1 Uni-directional without lock.
- Post Height: 1000 mm / 39.42 in.
- Barrier Length: 900 mm / 35.42 in.
- Barrier Thickness: 32 mm / 1.25 in.
- Post Diameter: 106 mm / 4.16 in.

LOCK OPTIONS

- WS 1 Uni-directional without lock.
- WS 2 Bi-directional without lock.
- WL 1 Uni-directional with mechanical lock.
- WL 2 Bi-directional mechanical lock.
- WE 1 Uni-directional with electric lock.
- WE 2 Bi-directional with electric lock.

ACCESSORIES

- Remote control unit.
- Stainless steel opposite post.
- Posts for access control units.
- LED indicators.